



NIMBLY



Vertical machine
Macchina verticale
Machine verticale

**BREAK THE LIMITS,
BE UNBREAKABLE.**



**THE ROTATING ARM
FOR YOUR NEEDS**

The strength of a... rotating arm. Nimbly is a Semi-Automatic wrapping machine with rotating arm which provides highly-reliable operation and ease of use.

La forza del braccio... rotante. Nimbly è l'avvolgitore Semi-Automatico a braccio rotante dalla grande affidabilità operativa e semplicissimo da utilizzare.

La force du bras... tournant. Nimbly est la banderoleuse Semi-Automatique à bras tournant d'une grande fiabilité opérationnelle et facile à utiliser.



NIMBLY

Vertical machine
Macchina verticale
Machine verticale

WHY NIMBLY?

- Ideal for unstable loads.
- Can memorize up to 6 wrapping cycles
- Inexpensive rotary arm still capable of using 16 kg reels.

PERCHÈ NIMBLY?

- Perfetto per pallet instabili.
- Può memorizzare fino a 6 cicli di avvolgimento.
- Braccio rotante economico ancora in grado di utilizzare bobine da 16 kg.

POURQUOI NIMBLY?

- Idéal pour palettes instables
- Elle peut mémoriser jusqu'à 6 cycles de banderolage
- Bras rotatif peu coûteux toujours capable d'utiliser des bobines de 16 kg.



**Safety edge on column
for emergency stop.**

*Dispositivo di sicurezza
per arresto d'emergenza.*

*Bord de sécurité sur la colonne
pour l'arrêt d'urgence.*



Layout NIMBLY

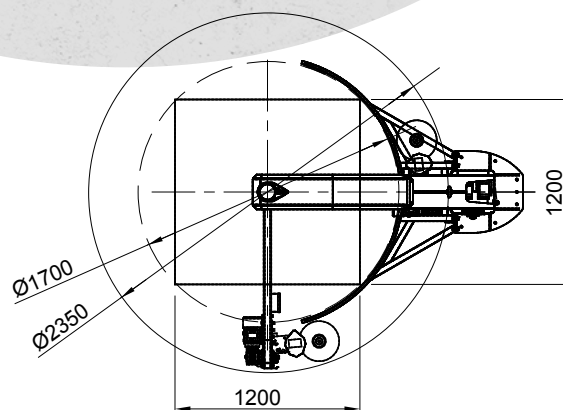
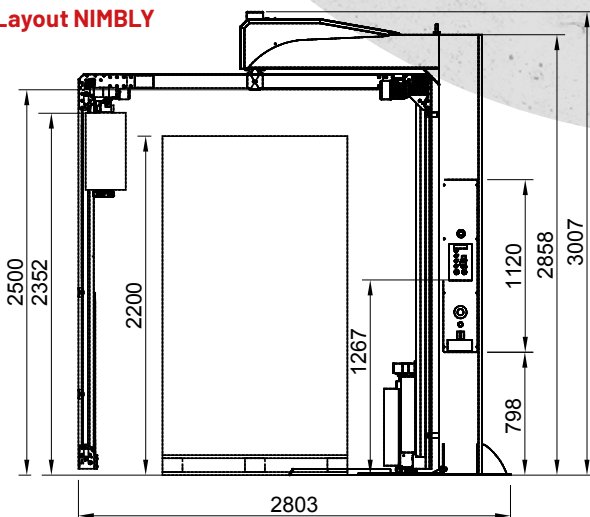

Control panel
Quadro comandi
Tableau de commande

Available with 2 carriage types
 Disponibile con 2 tipi di carrelli
 Disponible avec 2 types de chariots

MB

Mechanical brake
 Freno meccanico
 Frein mécanique



EB

Electromagnetic clutch
 Frizione elettromagnetica
 Frein électromagnétique

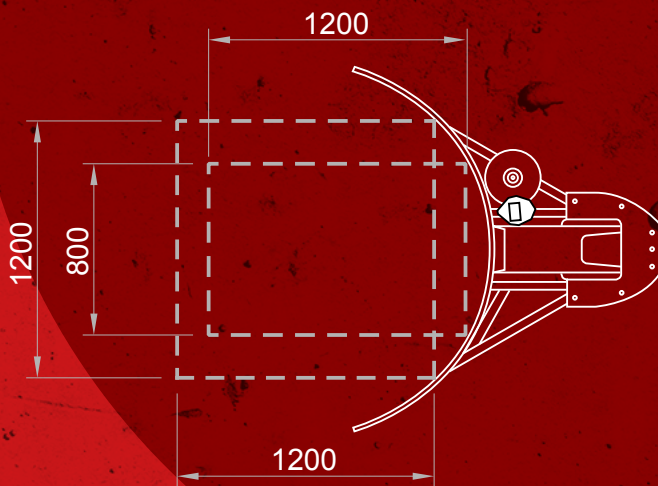

Stopping bar for pallet alignment.
 Sistema per allineamento pallet.
 Système pour l'alignement des palettes.

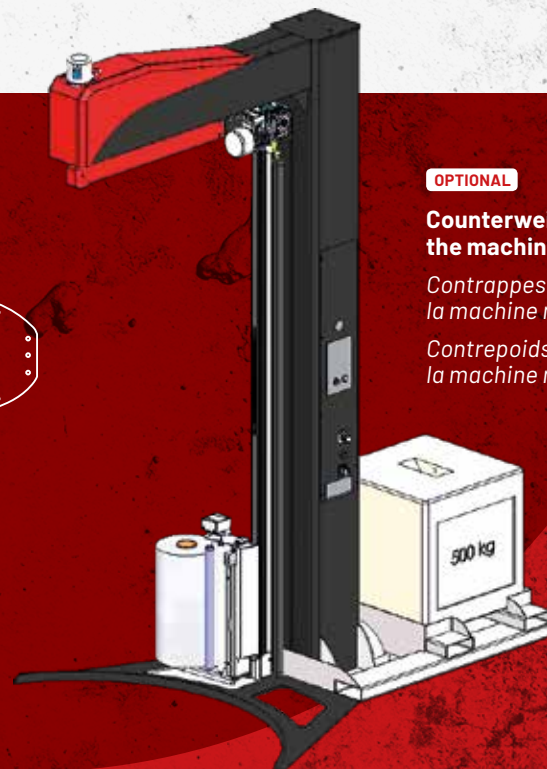

OPTIONAL

Counterweight making the machine mobile
 Contrappeso per rendere la machine mobile
 Contrepoids rendant la machine mobile

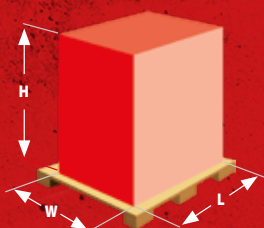

NIMBLY	
Ø	1700
L	1200
W	1200
H	2200



OPTIONAL

Automatic film cutting system
 Sistema di taglio automatico del film
 Système de coupe automatique du film



OPTIONAL

Manual roping device
 Cordonatura manuale
 Dispositif de cordage manuel

NIMBLY



Web app for the management control of the state of machines, assistance, rental, etc.

Applicativo web per il controllo gestionale dello stato macchine, assistenza, noleggio, ecc

Application web pour le contrôle de gestion de l'état de la machine, de l'assistance, de la location, etc.

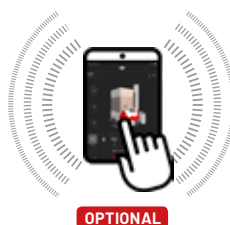

"DeTouch" Technology for remote control and monitoring of your machines with any mobile device.

Tecnologia "DeTouch" per il controllo e monitoraggio della macchina da remoto con ogni dispositivo.

Technologie "DeTouch" pour le contrôle et la surveillance à distance de vos machines avec n'importe quel appareil mobile..

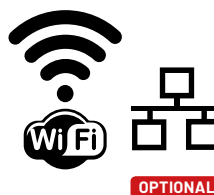

Remote control of all parameters from PC, Tablet or Smartphone

Controllo remoto di tutti i parametri tramite PC, Tablet o Smartphone

Contrôle à distance de tous les paramètres via un PC, une tablette ou un smartphone.

TECHNICAL FEATURES

- Gradual rotation start/stop controllable by inverter
- Carriage up/down speed controllable by independent inverter
- Acoustic signal at cycle start and stopping in phase at cycle end
- Emergency stop button compliant with CE standards
- Machine reset button compliant with CE standards

CARATTERISTICHE TECNICHE

- Partenza/arresto della rotazione graduale e regolabile con inverter
- Velocità salita/discesa carrello regolabile con inverter indipendente
- Segnale acustico avvio ciclo e fermata in fase a fine ciclo
- Pulsante a fungo di emergenza secondo norme CE
- Pulsante di riarmo macchina in funzione secondo norme CE

CARACTERISTQUES TECHNIQUES

- Démarrage/arrêt de la rotation progressive et réglable par inverter
- Vitesse du chariot réglable en montée et en descente avec inverseur indépendant
- Signal acoustique de début de cycle et d'arrêt en fin de cycle
- Bouton coup de poing d'urgence conforme aux normes CE
- Bouton de réinitialisation de la machine en marche selon les normes CE

PARAMETERS ADJUSTABLE FROM CONTROL PANEL

- Separate number of wraps on pallet top/bottom
- Variable rotation speed
- Separate carriage up/down speeds
- Photocell sensing delay
- Buttons for manual machine operation
- Display for operating values
- Separate film tension for up/down (except MB)

PARAMETRI REGOLABILI DA QUADRO COMANDI

- Giri separati alla base/sommità del pallet
- Velocità rotazione regolabile
- Velocità separate salita/discesa del carrello
- Ritardo lettura fotocellula
- Pulsanti di gestione manuale della macchina
- Visualizzatore di quote
- Tensione film separata salita/discesa (escl. MB)

PARAMETRES REGULABLES DEPUIS LE TABLEAU DE COMMANDE

- Tours séparés à la base et au sommet de la palette
- Vitesse de rotation réglable
- Vitesse séparée de montée et de descente du chariot
- Retard de lecture de la photocellule
- Boutons de commande manuelle de la machine
- Afficheur de cotes
- Tension du film séparée haut/bas (sauf MB)

STANDARD CYCLES SELECTABLE FROM PANEL

- Up and down
- Up or down only
- Manual cycle

CICLI BASE SELEZIONABILI DA QUADRO

- Ciclo salita e discesa
- Ciclo solo salita/solo discesa
- Ciclo manuale

CYCLES DE BASE SELECTIONNABLES DEPUIS LE PANNEAU

- Cycle montée et descente
- Cycle seule montée/descente
- Cycle manuel

ADDITIONAL FUNCTIONS FOR STANDARD CYCLES

- Top sheet application
- Wrapping cycle with display for values
- Reinforcement wraps with manual button
- Wrapping cycle by layers

FUNZIONI ATTIVABILI SU CICLO BASE

- Ciclo mettifoglio
- Ciclo con visualizzatore di quote
- Avvolgimenti di rinforzo con pulsante manuale
- Ciclo a strati

FONCTIONS ACTIVABLES SUR CYCLE DE BASE

- Cycle dépose de coiffe
- Cycle avec afficheur de cotes
- Banderolage de renfort avec bouton manuel
- Cycle par couches



BREAK THE LIMITS,
BE UNBREAKABLE.

PKG s.r.l.
Via Torrianese, 58
47824 Poggio Torriana (RN) Italy

Tel. +39 0541 627063 _ Fax +39 0541 675448
info@pkg-group.com

www.pkg-group.com

